

PROTECT YOUR DOCK NEXT WINTER WITH A DOCK DE-ICER SYSTEM

Prevent freezing from occurring around your dock in winter with the very best in dock de-icer systems. Durable and energy-efficient!

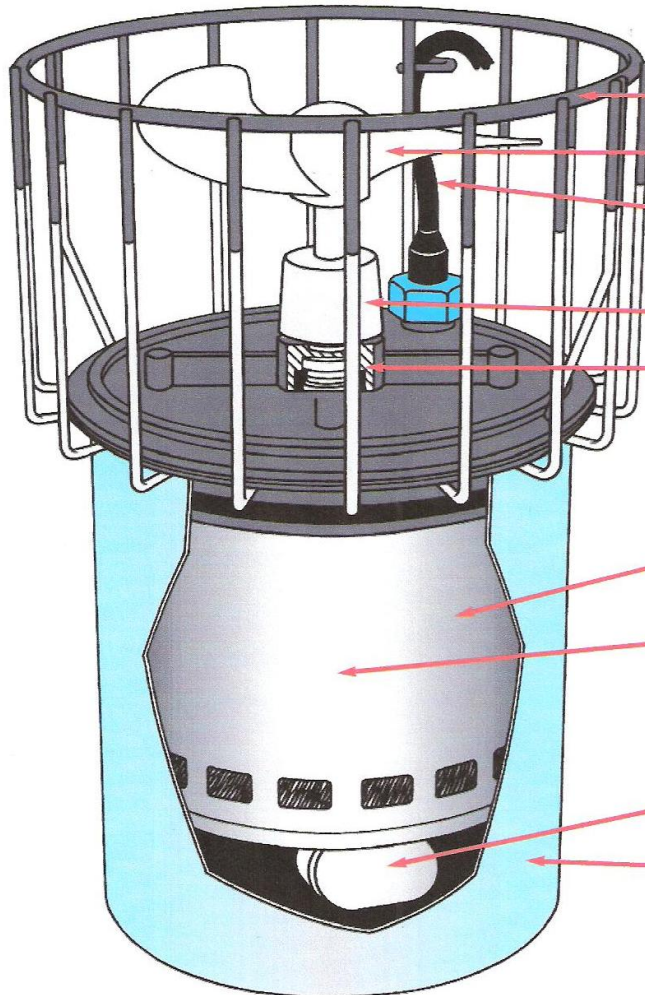

SUSPENSION ROPES — hollow braided polypropylene. 20 feet x 5/16 inch, 2 lengths attached.

STAINLESS STEEL SAFETY CAGE — for propeller protection. Vinyl coated for easy handling.

PERFORMANCE PROPELLERS — specially pitched for maximum thrust and minimum power usage.

POWER CABLE — 25 foot water and oil resistant power cable with cold weather flexibility to -50°F. Exterior water-tight connection for easy on-the-spot replacement. Optional lengths are available.

ZINC ANODE — renewable anode for corrosion protection due to electrolysis.

SEALS — Kasco Dual-Sealed system. Hard face internal mechanical oil seal and outside lip seal for double protection against leaks.

SHAFT — #316 series stainless steel, approved for salt water use.

BEARINGS — ball type, top and bottom. Flood oil lubricated for excellent heat dissipation.

OIL — large capacity dielectric oil provides maintenance-free lifetime lubrication, maximum cooling and protection against failure due to moisture contamination.

MOTOR — custom designed, continuous duty 120V single phase, oil immersed and overloaded protected with fully automatic reset.

(240V 3/4 and 1 H.P. models are available by special order)
 F2400/D, 1/2 H.P. with 26 lbs. of thrust – 5.0 amps at 120V
 F3400/D, 3/4 H.P. with 34 lbs. of thrust – 6.7 amps at 120V
 4400/D, 1 H.P. with 52 lbs. of thrust – 11.2 amps at 120V

CAPACITOR — permanent split capacitor (PSC) insures quick high torque starts and smooth operation.

MOTOR HOUSING — corrosion-resistant stainless steel, a must for salt water operation.

Motor exceeds NEMA specifications

Shipping weight — F2400/D, 25 lbs.
 F3400/D, 35 lbs.
 4400/D, 40 lbs.

Overall dimensions — F2400/D, 9" x 11 1/2"
 F3400/D and 4400/D, 9" x 14"

Which model is right for you?

Model	Size	Thrust	Typical Open Area
FD2400	1/2 HP	26 lbs.	Up to 50' diameter circle
FD3400	3/4 HP	34 lbs.	Up to 75' diameter circle
FD4400	1 HP	52 lbs.	Up to 90' diameter circle

Power Cords available in 25 ft, 50 ft and 100 ft.

Environmentally friendly vegetable-based motor oil available.

Accessories: Thermostat or Combination Thermostat / Timer
 Dock Mounting Kit (required for some dock installation applications)
 Horizontal Float

Graham
 Marine Construction

250-229-2169

www.grahammarine.ca